

GENERAL INFO

REVERSE OSMOSIS UNDERSINK WATER FILTER SYSTEM WITH BOOSTER PUMP*

Compact design that includes a built-in booster pump. When only the purest water will do.

It's the latest in Reverse Osmosis, a filtration process for high purity water. The ultra-fine membrane operates by rejecting impurities and flushing them out via the drain line. This effectively eliminates 98% of all dissolved impurities, heavy metals, salts, viruses, bacteria, cysts, fluoride & chloride, taste, odour and chemicals. Only pure, sparkling-clear water from your own water supply is left for your health, safety and peace of mind.

The Puretec CO-RO270 Series reverse osmosis filter system equipped with booster pump* is designed to increase the water pressure going into the RO unit. The Booster pump provides a reliable inlet pressure for efficient membrane utilisation. These pumps are capable of continuous duty and are effective for recirculation based applications as well.

FEATURES & BENEFITS

- Fluoride removal.
- Pure, safe water at your fingertips.
- 0.0005 micron rating for 98% removal of impurities.
- No bacteria build-up through integrated flushing.
- Models with booster pump included provide a reliable inlet pressure for efficient membrane utilisation and are ideally suited for continuous duty.



CO-RO270P SYSTEM



STORAGE TANK OPTIONS: 75L, 37L & 16L

DIAGRAM & FILTRATION TECHNOLOGY

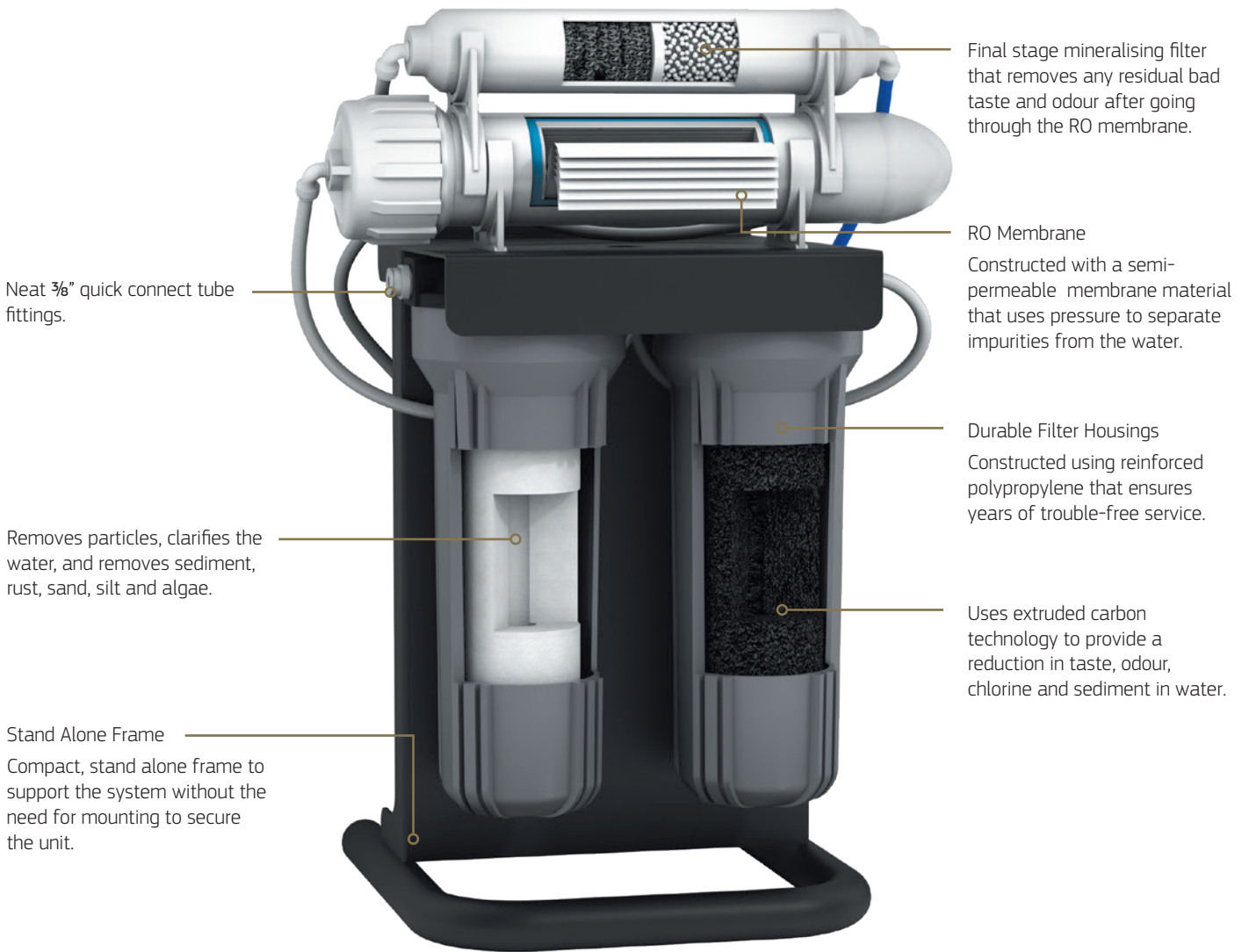

Built-in pressure pump included with CO-RO270P models.



SPECIFICATIONS

| Ordering Code | CO-R0270 | CO-R0270P | CO-R0270P-16 | CO-R0270P-37 | CO-R0270P-75 |
|--------------------------|----------------------|--------------|--------------|--------------|--------------|
| Replacement Cartridges: | | | | | |
| Sediment Cartridge: | PX051 | | | | |
| Taste & Odour Cartridge: | CB101 | | | | |
| RO Membrane : | RET-1812-75 | | | | |
| Inline Mineraliser: | IL146 | | | | |
| Flow Rate: | 284 Lpd | | | | |
| Micron Rating: | 0.0005 micron | | | | |
| Storage Tank Model: | CO-T4.2 | Not Included | CO-T4.2 | CO-T10 | CO-T20 |
| Storage Tank Capacity: | 16L | - | 16L | 37L | 75L |
| Booster Pump Model: | Not Included | RA-P100 | | | |
| Booster Pump Volts: | - | 24VDC | | | |
| Booster Pump AMPS: | - | 0.35 | | | |
| Booster Pump Flow Rate: | - | 2 Lpm | | | |
| Max Pressure: | 520 kPa | | | | |
| Connection: | 3/8" | | | | |
| Warranty: | 3 years [^] | | | | |

Important Note Use only genuine Puretec replacement cartridge. 3 year warranty is 1 year parts and labour plus 2 years parts only. Excludes consumables. *Booster pump only included with CO-R0270P models. Storage tank included with models as indicated.

PRODUCT DIMENSIONS (measurements shown in millimetres)

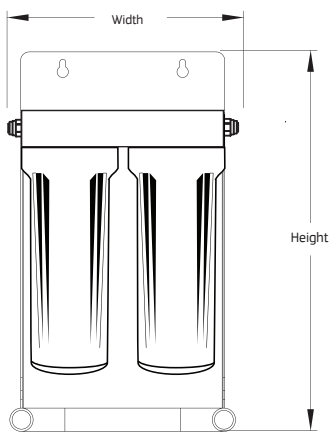

CO-R0270 & CO-R0270P
 437 (H) x 245 (W) x 262 (D)

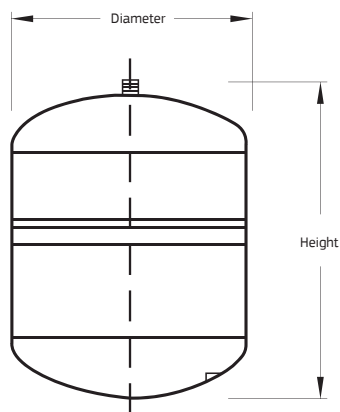

CO-T4.2
 385 (H) x 250 (D)

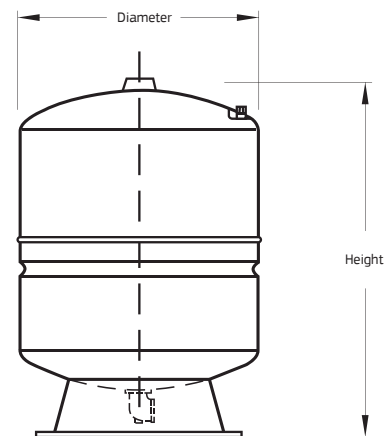

CO-T10
 580 (H) x 390 (D)
CO-T20
 780 (H) x 389 (D)