

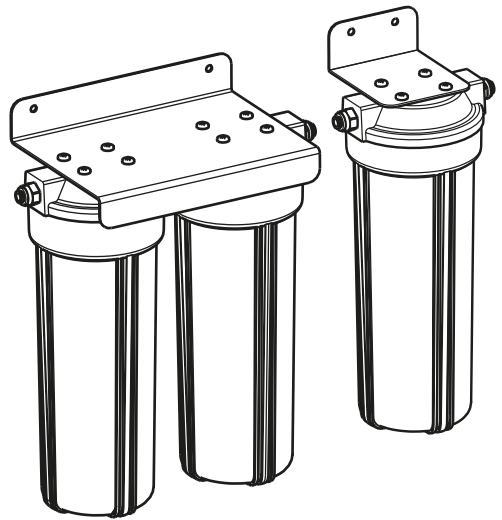

**Puretec**<sup>®</sup>  
BASIC



# User Guide

## SIB / TW Series

Drinking Water Filter Systems

## Puretec Customer Service

Thank you for purchasing a Puretec Basic undersink drinking water system. Your system is a proven performer manufactured from only quality materials and components and will give years of 'spring fresh' water free of impurities if maintained properly.

The system is designed for metropolitan supply water but can be used in other situations. For other types of water supply please contact your stockist.

The Puretec Basic filter systems cartridges need replacing regularly to maintain optimum performance. This is a simple procedure when following instructions. For cartridge replacements contact your stockist.

## Operation

The Puretec Basic undersink systems are designed to run economically for many years and this is dependant on the initial installation and periodical maintenance.

Flush systems for 10 minutes after any period of non-use more than 2 days. For a period of non-use of 2 weeks or more, it may be necessary to replace cartridges.

Caution: Do not use with water that is microbiologically unsafe or with water of unknown quality without adequate disinfection before or after the system.

## Cartridge Replacement

To maintain the high quality of the purified water the cartridges need changing every 6 months (this is dependant on water quality and usage).

You can obtain replacement cartridges from your dealer and to maintain performance, and warranty use genuine Puretec replacements.

## Cartridge Installation/Replacement

To change the filter cartridges adhere to the following procedure:

1. Close Ballvalve to prevent water flow.
2. Relieve water pressure by operating faucet lever.
3. Unscrew filter housing bowl using the spanner wrench and discard cartridges. When removing housings place a container underneath to catch any spillage.
4. Cleanse the inside of the housing using hot water and detergent. Check O-Ring and lubricate with food grade silicone lubricant or similar. Replace O-ring if kinked or damaged.

5. Install new cartridges and replace housing screwing them up **HAND TIGHT ONLY**. Sediment filter is on the inlet side and chemical on the outlet side.
6. Restore water supply & check for leaks, rectifying them, if any, before leaving the unit.

After installing cartridges flush unit for 5 - 10 minutes.

## Installation

This system comes complete with an installation kit enabling it to be connected to existing 15mm (½") copper pipe (copper pipe NOT included) Connect to cold supply only - hot water should be filtered prior to heating. Included is a control valve incorporating backflow prevention, anti hammer, flow control and pressure limiting capabilities according to The Australian Standards in full compliance with the relevant laws. **Note:** the PLV is standard in selected systems.

**Installation Note:** A water filter system/tap, like any product, has a limited life and may eventually fail. Also sometimes failure happens early due to unforeseen circumstances. To avoid possible property damage, this product should be regularly examined for leakage and/or deterioration and replaced when necessary. A drain pan, plumbed to an appropriate drain or outfitted with a leak detector, should be used in those applications where any leakage could cause property damage, and/or the water supply should be turned off if no one is home/present.

**INSTALLATION MUST BE COMPLETED BY A LICENCED PLUMBER. FAULTY OPERATION DUE TO UNQUALIFIED PERSONS WILL RESULT IN VOIDED WARRANTY COVERAGE.**

## Installation Requirements

1. 15mm (½") Cold water line.
2. Supply pressure: 300 - 520 kPa (when pressure exceeds 520 kPa a pressure limiting valve must be fitted).
3. Supply temperature: 0° - 30°C (protect from freezing).
4. Suitable location for faucet.

Alternative fittings may be required if being connected to anything other than existing 15mm (½") copper pipe (copper pipe NOT included). No electrical or drainage requirements needed.

## Installation Procedure

1. Select suitable location that is close to the point of filtered water delivery (eg. sink). Remember to allow access room for changing filters and a suitable place where water spillage will not cause damage. Location should not be in direct sunlight.

2. Isolate water supply and cut existing pipe ready to install the ball valve.
3. Connect the ball valve to the multivalve (if included, PL models) with a piece of white tubing (see figures 1 & 3). Flush with a small amount of water to remove any debris.
4. Choose the best position for the faucet, taking into consideration height and also the drainage of any spills. Then drill a 12mm hole and install the faucet as in Step 5.
5. To install faucet, place the small rubber washer, chrome washer and large rubber washer on to the threaded end of the faucet (see Fig. 1). Insert the faucet into the hole in sink or bench. Slip the large plastic washer and lock washer onto threaded end of faucet and screw on nut and tighten making sure faucet is correctly positioned on top of the counter.
6. Install housing assembly by positioning it in the desired location, marking the position of fixing holes and fixing with mounting screws. (Quick Connect Series can be mounted horizontally) Allow room for the connecting tubes and for removing the filter bowls (50mm).
7. Fit Tubing into connectors (for quick-connect fittings see Fig. 3). Allow slack in the tubing. Make sure flow is right according to inlet outlet on housing assembly. For faucet connection (see Fig. 2).
8. Install cartridges as per Cartridge Installation/Replacement.
9. Restore the water supply and check for leaks. The filters need to be only hand tight. If they leak then undo housing and check the O-ring is seated properly.
10. Run the system for at least 10 minutes (push the faucet lever to the upright position) to remove carbon fines. Water may appear milky, but this is normal and is only tiny air bubbles that will clear after a short period.

## Use Guidelines

- Minimum operating pressure 80kPa.
- Maximum operating pressure 520kPa.
- Do not allow exposure to temperatures below 0°C, protect from freezing.
- Maximum operating temperature 38°C.
- Nominal flow rate 4 Lpm.
- This system must be installed according to local plumbing codes on the cold water line.
- Replacement Cartridges: See Cartridge Installation
- This system requires regular replacement of the filter cartridge to maintain proper operation. Varying chlorine, sediment, or organic substance levels may affect replacement frequency.
- Be sure to change the filter cartridge at least every 6 - 12 months which ever occurs first; or whenever you detect a change in taste, odour, or decrease in flow.

**Caution:** Do not use with water that is microbiologically unsafe or of unknown quality without adequate disinfection before or after the system.

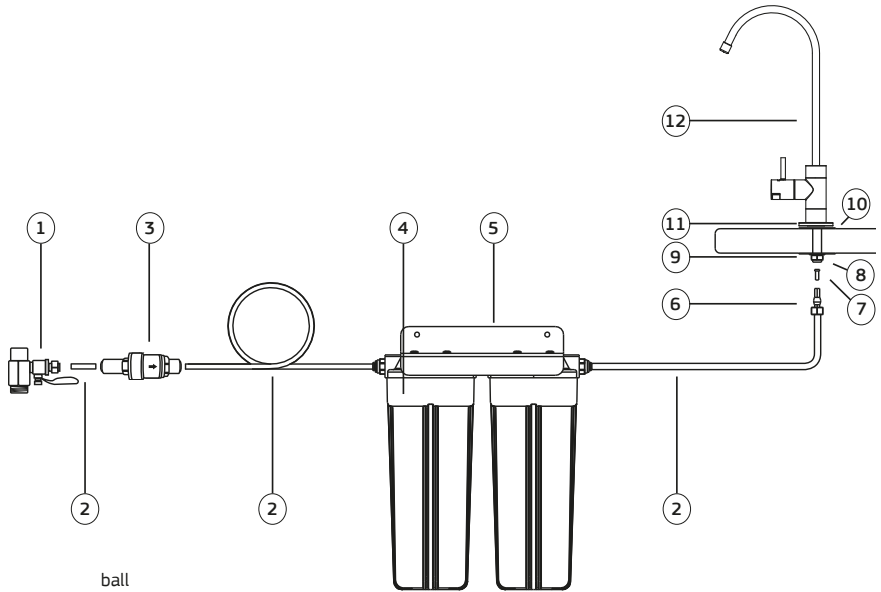
**Figure 1 - Parts Diagram**

No.	DESCRIPTION
1	Ball Valve Adaptor
2	Flexible Tubing
3	Pressure Limiting Multivalve (if included, PL models)
4	Housing Assembly (Twin Pictured)
5	Mounting Bracket
6	Tube, Nut and Ferrule
7	Tube Insert
8	Faucet Lock Nut and Washer
9	Black Plastic Washer
10	Black Rubber Washer
11	Escutcheon Plate
12	High Loop Faucet

**Figure 2 - Faucet Diagram**

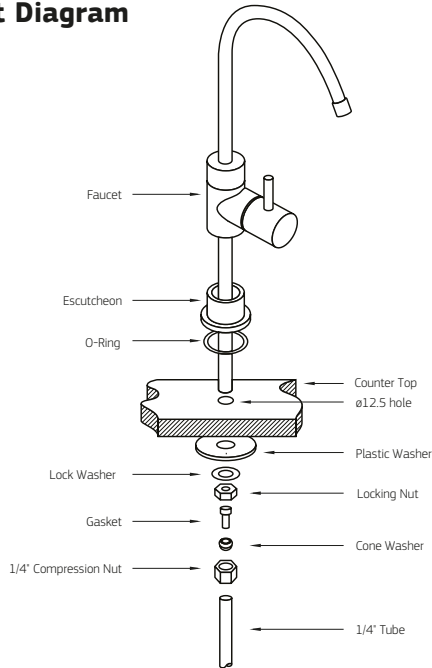

**Figure 3 - How To Use Quick Connect Fittings**



1. Cut the tube square and push in to the tube stop. For metal tube remove burrs and chamfer tube end to prevent O-Ring seal being damaged.

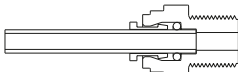

3. Tube is secured in position.

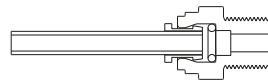

2. Fitting grips before it seals. Ensure tube is pushed in to tube stop.

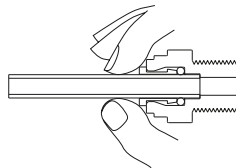

**DISCONNECTION PROCEDURE**

4. Push collet against body and slide tube out of fitting.

## Notes

All pictures and information are supplied as a guide only. The complete range of Puretec products are developed, refined and made to meet and exceed stringent specifications for the worldwide market.

Important Note: Sales of products are subject to our Terms & Conditions which are available upon request. All specifications, prices and photos are a guide only and are subject to change without notice. Please ring to confirm details. Do not use products with microbiological unsafe water without adequate disinfection. Where water pressure exceeds maximum pressure specifications, a pressure limiting valve must be fitted. Maximum flow depends on cartridge, vessel, pressure, impurities etc.

All installation and service work should be completed by qualified & licenced tradespeople. Faulty operation due to unqualified persons will result in voided warranty coverage.

## Warranty

Any claim under this warranty must be made within 1 year of the date of purchase of the product. This product is warranted to be free of defect of material and workmanship for 1 year from date of purchase. To make a claim under the warranty, take the product and proof of purchase to place where you purchased the product, and they will lodge a Warranty Request with Puretec. 1 year warranty is 1 year parts and labour.

Puretec will pay your reasonable, direct expenses of claiming under this warranty. You may submit details and proof of your expense claim to place of purchase for consideration.

The warranty only applies if the product was used and/or installed in accordance with the user guide and/or installation instructions. This warranty is given in lieu of all other express or implied warranties and manufacturer shall in no circumstance be held liable for damages consequential or otherwise or delays caused or faulty manufacturing except as excluded by law.

Applicable to all above, is that the warranties need to be approved by Puretec to ensure product was not incorrectly used, installed or claimed. False and incorrect claims will be pursued at Puretec's discretion, including chargeable inspection and labour costs incurred.

## Warranty/Australia

This warranty is given by Puretec Pty Ltd, ABN 44 164 806 688, 37-43 Brodie Road, Lonsdale SA 5160, telephone no. 1300 140 140 and email at sales@puretec.com.au.

This warranty is provided in addition to other rights and remedies you have under law: Our goods come with guarantees which cannot be excluded under the Australian Consumer Law. You are entitled to replacement or refund for a major failure and to compensation for other reasonably foreseeable loss or damage. You are also entitled to have the goods repaired or replaced if the goods fail to be of acceptable quality and the failure does not amount to a major failure.

## Warranty/New Zealand

This warranty is given by Puretec Ltd, Reg. No 4464398, PO Box 875 Cambridge 3450 NZ, telephone no. 0800 130 140 and email at sales@puretec.co.nz.

This warranty is provided in addition to other rights and remedies you have under law: Our goods come with guarantees which cannot be excluded under the Consumer Guarantees Act. You are entitled to replacement or refund for a major failure and to compensation for other reasonably foreseeable loss or damage. You are also entitled to have the goods repaired or replaced if the goods fail to be of acceptable quality and the failure does not amount to a major failure.



**Puretec**<sup>®</sup>  
PERFECTING WATER

**AUSTRALIA**

P 1300 140 140

E [sales@puretec.com.au](mailto:sales@puretec.com.au)

W [puretec.com.au](http://puretec.com.au)

**NEW ZEALAND**

P 0800 130 140

E [sales@puretec.co.nz](mailto:sales@puretec.co.nz)

W [puretec.co.nz](http://puretec.co.nz)